

LCD 2.5 display





Content:

1. Quick-start	4
2. Function of each button	6
3. Display content	10
4. Settings	12
5. Imprint	16

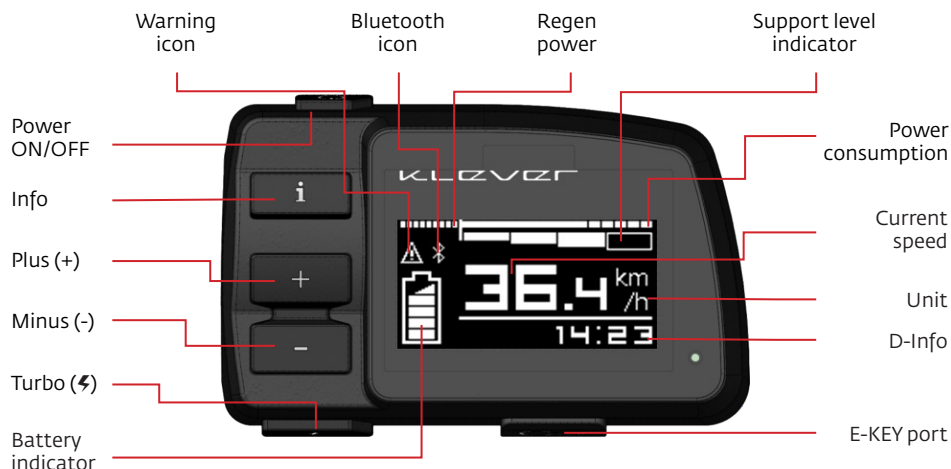

Image 1

1. Quickstart

This Display (with user interface) is your gate to Klever's electric propulsion system, BIACTRON (Image 1). With the display you start and control the electric drive system.

You can start the system with or without inserting the E-KEY.

When the E-KEY pairing function is enabled, the bicycle has its own individually programmed display. In this case your Klever bike can only operate an E-KEY with the same ID. It is not possible to activate your Klever bike with an E-KEY of another bike. Each Klever bike will be delivered with two identical E-KEYs.

Every press of a button will be confirmed with a short acoustic signal.

As soon as you insert the E-KEY into the display, the system will start. With the E-KEY already in the display while the system is off, there are two ways to activate the system:

1. Press the power button (Image 1), the system runs a system check for 3 seconds - now the system is activated.

or

2. When you start pedalling the system will wake up automatically. After 3 seconds of system check, the electric drive will start to support.

Button	Location	Function
Power	Upper left edge	On / Off
Info	Top left	Switch between clock, range, trip, odo, SOC and fitness data
Plus (+)	Middle left	Increase support level
Minus (-)	Lower left	Reduce support level
Turbo	Lower left edge	Starting and pushing aid (at rest); strongest support (while pedalling)

2. Function of each button



Image 2

Start/ stop button (Image 2)

By pressing the POWER button you'll boot the system. The system performs a system check of 3 seconds, and the drive system is ready to operate. The electric drive will start to support depending on the level of assistance chosen.

By pressing this button again, the system will be turned off and all settings are being stored.

Press the button again, the system starts and all previous settings and levels of support are enabled again.



Image 3

PLUS (+) Button (Image 3)

By pressing the PLUS (+) button you can increase the support level. For instance, when the selected level is M (medium) and you press the PLUS (+) button, the support level of the motor will increase to H (high).



Image 4

MINUS (-) Button (Image 4)

By pressing the MINUS (-) button you can reduce the support level. For instance, when the selected level is M (medium) and you press the MINUS (-) button, the support level of the motor will decrease to L (low).



Image 5

INFO Button (Image 5)

By pressing the INFO button, subsequently all rider's information can be displayed on the LCD-screen.

Press the INFO button shortly in order to go through the available rider's data: **Time, SOC, trip, km-day, odo, kcal.** See below.

Please note: the available data may vary depending on bike model and software version.

Press "INFO key" to change D-INFO

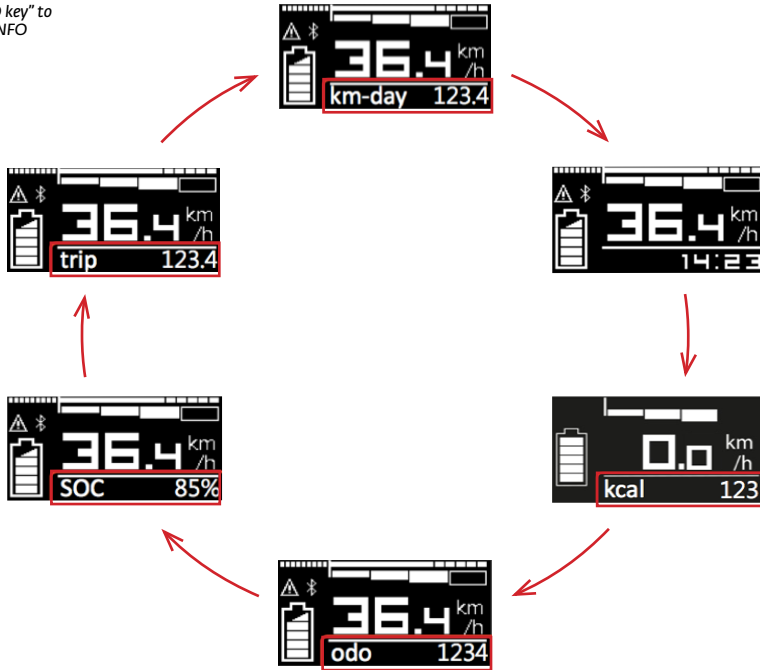

Image 6

Time (hh:mm) (Image 7)

The time can be adjusted by the settings menu of the display, by synchronising with your smartphone or with the Klever service tool at you local dealer.



Image 7

SOC (State of Charge) (Image 8)

The SOC indicates the current battery capacity by %, in this case 85%.



Image 7



Image 9

Trip (Image 9)

Kilometres ridden since the last reset, in this case 123.4 km.

If you want to reset the trip distance to zero at the start of a new trip, press the INFO button long and select RESET in the menu. Then select trip, then confirm by long pressing the ENTER (+) button. See page 11.



Image 9-1

Km-day (Image 9-1)

Kilometres ridden today, starting at 00:00, in this case 123.4 km.

The daily mileage will be set to zero at midnight 00:00 every day.



Image 10

odo (Image 10)

Accumulated kilometres during the lifecycle of your Klever, in this case 1234 km. When the odo reaches 99999 km. it will be reset to 0.



Image 10-1

Kcal (Image 10-1)

The number of kilocalories burnt by the cyclist, in this case 123 kcal.

For proper kcal calculation please set the rider's weight. Press the INFO button long and select "Rider" to input the weight number. Kcal can be reset by selecting RESET in the menu. See page 11.

TURBO Button (⚡) (Image 11)

This button has two functions:

1. As a starting and pushing aid:

to help you push or start a bicycle at a traffic light, on a ramp or uphill just press this button.

When the ⚡ (TURBO) button is pushed without pedalling, the "throttle" mode provides motor output:

- < 18 km/h at H
- < 12 km/h at M
- < 4 km/h at L

When you release the button, the motor support instantly stops.

2. As a turbo support while pedalling.

When you need extra support for a short period of time, for example on a steep ramp, press the button and you get the highest possible support from the motor.

Turbo mode only works while pedalling. The turbo assistance from the motor will stop when you stop pedalling or when you release the button.



Image 11



Please note: driving with a starting aid/turbo mode has to be learned. Practice this procedure only on a quiet street or parking lot. Only when you have familiarised yourself with the additional turbo support. You can ride on a public road.



Please note: using the turbo mode as a pushing aid to roll your Klever bike out of the garage, or roll it up a ramp, please make sure that you have selected the L program. When using the pushing aid in the M or H mode, you may have serious difficulty to keep the pace of the bike.

3. Display content

Battery status (image 12)



Image 12

The battery icon shows the charging status of the battery. One bar represents 20% of full capacity (half bar represents 10%). If only one bar is shown, only 20% of the maximum capacity of the battery is available. Now the battery should be recharged.

When the battery icon is half of a bar only, there is less than 10% battery capacity remaining. Recharging of the battery is now urgently needed.

Display	Charging level
5 bars light up	100%
4 bars light up	80%
3 bars light up	60%
2 bars light up	40%
1 bar light up	20%
Half of bar lights up	Less than 10%

Additionally, you can check the charging status too with the LED on the front side of the battery.

In order to save the battery capacity, it is not possible to choose support level H in case only 10% battery capacity is left. With 5% remaining capacity it is only possible to use the L level.

Support level (Image 13)



Image 13

The bars in the upper part of the screen show the selected level of motor support.

In the right column of the table on page 8 we have listed recommended settings: for which situation which level of support will be the best of use. Of course, it is possible to select the levels according to your own liking, e.g. driving in the plane with the highest level of support (H).

System Level	Support	Driving situation (recommended)
UL (Ultra Low)	No support, system is activated	Downhill
L (Low)	Low support	Geringe ondersteuning
M (Medium)	Medium support	Matige ondersteuning
H (High)	High support	Hoge ondersteuning
⚡ (Ultra High) (while pedalling)	Strongest support	Steep ramps / violent gusts

Speedometer (Image 14)

The main display will show the current speed.



Image 14

Regeneration Power (Image 14-1)

This will show the regeneration power you get from the system in case you have selected the Recup mode in the menu:

1. While coasting: On (levels 1-2-3-auto) or
2. While braking: On (levels 1-2-3-auto)

*(braking regeneration is only available on 45 km kph Speed models). The more bars you see, the more regeneration you get from the system.



Image 14-1

Power consumption (Image 14-2)

This shows the actual power consumption. The longer or more bars, the more your battery is being drained. Of course, higher consumption will decrease your range more rapidly.



Image 14-2

4. Settings

Press „INFO button” long to enter the Setting menu

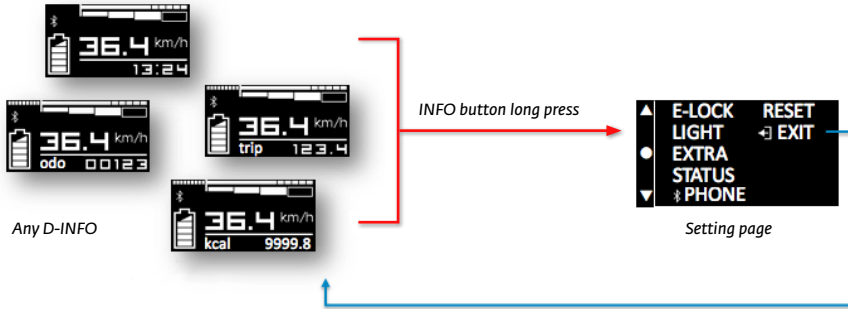

Image 15

Setting Menu

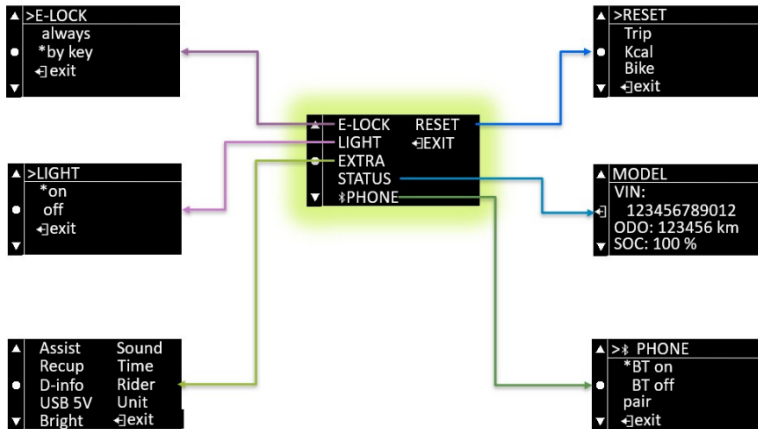

Image 16

Setting E-LOCK

The two E-KEYs which come with your bike are being paired with the E-drive system by your dealer. You have two options for the E-KEY functionality:

1. always

When you turn on the system the display will read "insert E-KEY". You have to insert the E-KEY to activate the system. In case you start to ride without inserting the E-KEY, then the alarm will set off and the motor will be locked.

Once you have inserted the E-KEY and the system is being activated, you can remove it and the system will continue to operate until you turn off the system. After that the motor lock is being activated. The next time when you turn on the system again, the display will ask again for the insertion of the E-KEY.

2. by key

The start-up procedure is the same, the display will ask to insert the E-KEY. In case you remove the E-KEY while the system is still on, the display will ask whether you want to lock the motor or not:

- a. Once you select "no", you can continue to cycle. The next time when you turn on the system, you don't need the E-KEY to activate the system.
- b. Once you select "yes", the system will be turned off and the alarm and the motor lock will be activated. In case you start to ride your bike now, the alarm will set off and the motor will be locked. In case you turn on the system with the Power button, then the display will ask you to insert the E-KEY again.

Setting LIGHT

You can decide to keep the head and tail light on or off when the system is on. Due to the EU regulations for Speed Pedelecs (45 kph), the head and tail light on Speed models will always be turned on automatically.

Setting EXTRA

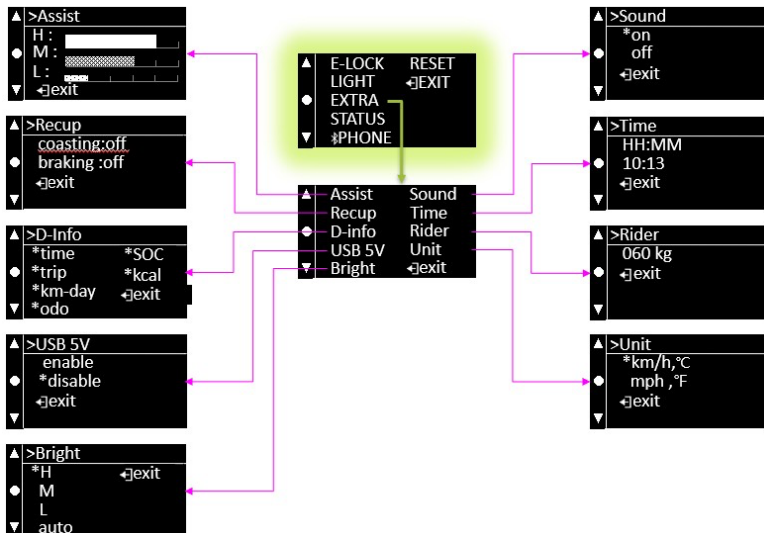

Image 17

With the EXTRA menu you have options to change the performance of the support system, change the major information you want to see while riding, change the unit/ rider weight etc.

Setting EXTRA > Assist

Five levels for each support mode (H, M, L) to meet different requirements. The factory defaults for each support mode is on three.

Setting EXTRA > Recup

Recup means the regeneration of energy back into the battery pack. Two recup functions: coasting regeneration and braking regeneration. The regeneration levels can be set from 1 to 3 or you can select the automatic mode; 1 = minimal regen and 3 = maximum regen. The factory default setting is off for both regen functions. Braking regeneration is only available on Speed models.

Setting EXTRA > D-Info

Six types of information can be shown on the major display by default. With a short press of the INFO or MINUS (-) button you can go through this information. And you can hide any of those in case you need them while riding.

Setting EXTRA > USB 5V

An extra wire comes from the display which allows you to connect the Klever USB charger for charging your device with 5V. This function is disabled by default. The USB charger is an optional accessory. Please ask the Klever team or authorised dealers.

Setting EXTRA > Bright

The brightness of the backlight can be adjusted.

Setting EXTRA > Sound

The volume of the system sound can be adjusted.

Setting EXTRA > Time

Time can be adjusted here or can be synchronised with your smartphone.

Setting EXTRA > Rider

Input the rider's weight for the proper calculation of the calorie output.

Setting EXTRA > Unit

Change the unit setting from km/h, °C to mph, °F.

Setting PHONE

You can use your smartphone as a dashboard to show the information from the bike system by Bluetooth connection.

Setting RESET

Trip and Kcal can be reset to zero. Or the bike setting can be reset to the factory default values.

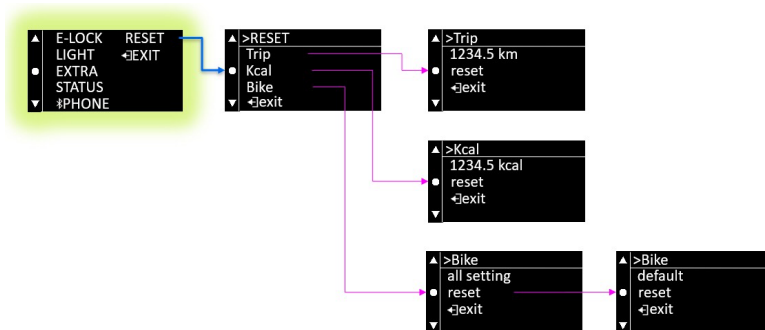

Image 18

5. Imprint:

Editor, photography, text, graphic design and text:

Klever Mobility Europe GmbH

Dieselstr. 8

D-50859 Köln

Tel: +49 2234 93 342 0

Fax: +49 2234 93 342 24

Mail: info@klever-mobility.com

Web: www.klever-mobility.com

Technical modifications regarding the information and illustrations in this manual are reserved.

A liability of publishers and other third parties for contributions from this manual and the fact devoted damages of any kind are excluded..

© Copyright

All rights reserved. Reprinting, translation and copying of any kind or any other use, such as on electronic media, even in part without written permission of the Klever Mobility Europe GmbH is not allowed.

May 2019 edition.

Klever Mobility Europe GmbH

Dieselstr. 8

D-50859 Köln

www.klever-mobility.com

Tel.: +49 2234 93342-0

Fax: +49 2234 93342-24

info@klever-mobility.com



Klever Mobility Europe

Klever Mobility NL b.v.

Afslag 8
3981 PD Bunnik
The Netherlands
tel. 0031 30 210 2905
infoNL@klever-mobility.com
www.klever-mobility.com